

HML Airflow Unit for Large Volumes

with Centralized Airflow Heating

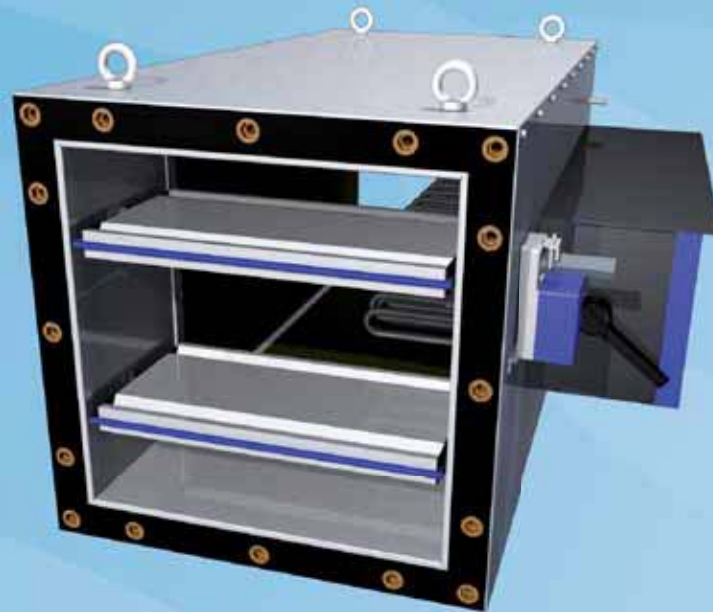

V2M05Y2007/Halton Marine reserves the right to alter products without notice.

Halton HML is a airflow unit for large air volumes with centralized airflow heating. The unit/s can be controlled with one room thermostat. HML VAV/CAV unit offers several regulation options from independent operation system to network applications. This pressure independent product may be equipped with reheater(s) from 900 W up to 30 KW.

- Integrated airflow measurement with built-in heat compensation
- Min. / max. airflow settings by software

- Triac controlled reheating coil(s), adjustable heating power by LRC software
- 90°C/120°C manual reset safety switch with state detection to CP-unit (control panel)
- Minimum flow alarm and inbox temperature measurement with overheat limit to cut-off reheater power
- Inputs to connect additional sensors e.g. pressure and ex-area temperature sensors available as an option
- Master/slave functionality: several units can be connected to one master unit
- All parameters can be preset at the factory or set onsite during commissioning by Palm handheld or laptop computer with LRC software

PART	MATERIAL	PART	MATERIAL
Casing	Hot galvanized steel or AISI316	Cables	Halogen free
Insulation	Mineral wool, s = 50 mm, MED approved	Measurement wings	Aluminium / polyurethane
I/O unit	Aluminium / plastic / electronics		
Reheat coil	Incoloy 800		

GENERAL HML drawings

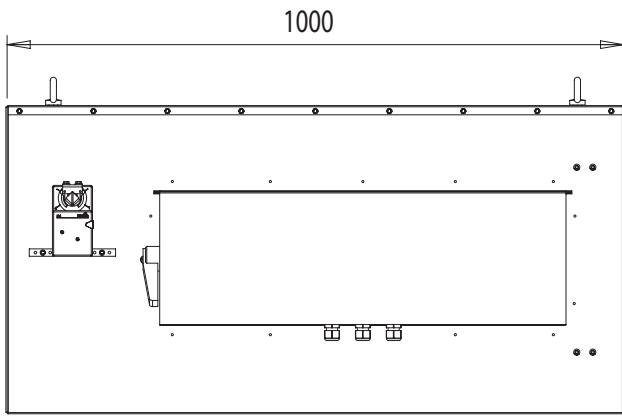

AIR FLOW

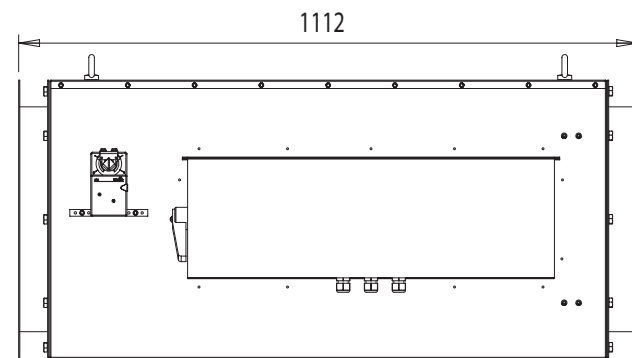
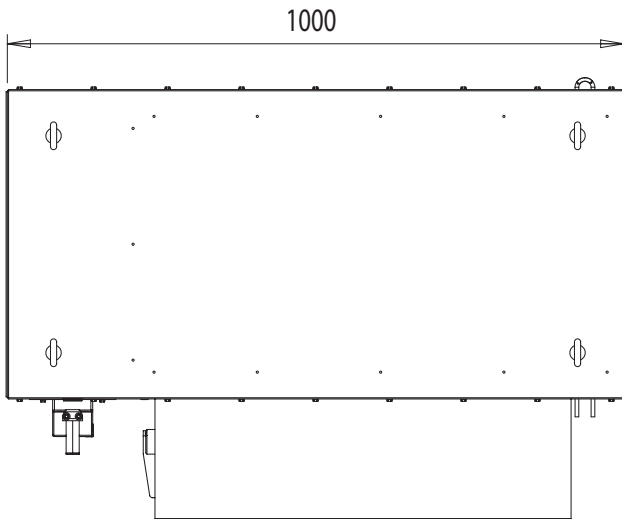
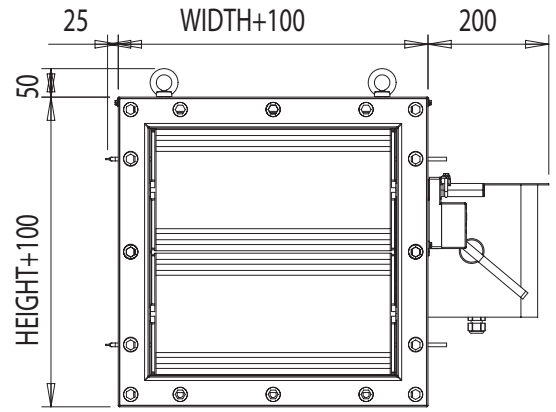

AIR FLOW

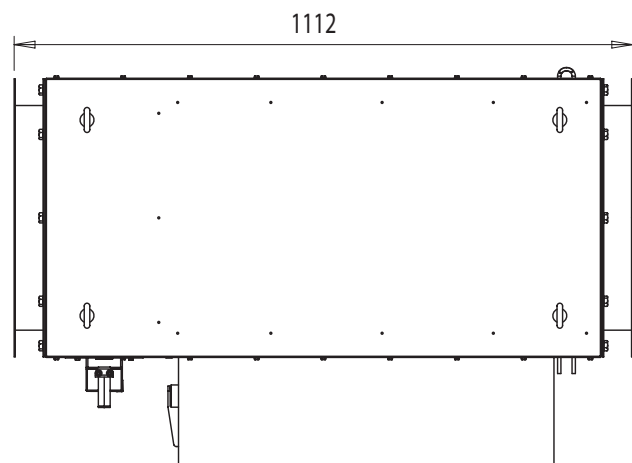
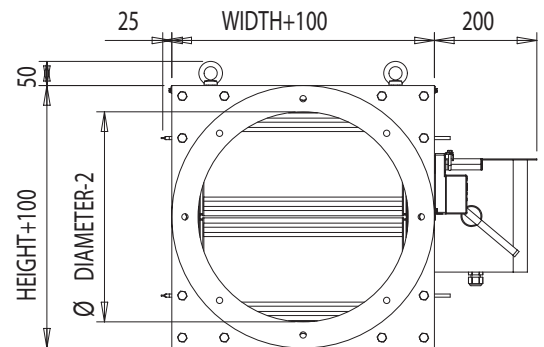

V2M05Y2007/Halton Marine reserves the right to alter products without notice.

Dimensions and reheater powers

Min. duct size	Min. airflow (m³/h)	Max. surface temp.	Power (W)	Current (A)	Voltage (V)	Ph
H200xW200	252	<120°C	900	4,4	230	1
H200xW200	360	<120°C	1350	6,4	230	1
H200xW200	468	<120°C	1800	8,3	230	1
H200xW200	612	<120°C	2400	11,0	230	1
H300xW300	900	<120°C	3060	4,6	400	3
H300xW300	1008	<120°C	4080	6,1	400	3
H300xW300	1260	<120°C	5100	7,6	400	3
H400xW400	1512	<120°C	6000	8,9	400	3
H400xW400	1800	<120°C	6900	10,2	400	3
H500xW500	2268	<120°C	9000	13,3	400	3
H600xW600	2968	<120°C	12000	17,6	400	3
H700xW700	4788	<120°C	16500	24,2	400	3
H900xW900	8856	<120°C	30000	43,9	400	3

Note:

Please note that the minimum duct size and minimum airflow must be followed in order to keep the heating coil surface temperature under the maximum level.

HML PRODUCT MODELS

Control Packages

- Independent options available
- Network options available

I/O unit (input/output unit)

- Connector for actuator (24VAC)
- Integrated airflow measurement sensor
- Minimum airflow alarm to cut off reheat power
- Triac to control reheat coils
- Connector for IC-cable
- Optional free inputs
- Connector for inbox temperature measurement (NTC sensor)
- Fuses to protect I/O, CP, triac and actuator
- Programming connector
- Two diagnose LEDs

CP unit (control panel)

Halton Marine HML airflow units are available with two different control panels; push buttons and rotating knob.

CP unit features

- Cabin temperature measurement (external measurement sensor possible)
- Two push buttons or knob adjusting available
- Self diagnose function (models B00 and C00)

- Internal fault LED
- Connector for IC-cable
- LED intensity control and auto dimming (models B00 and C00)
- Connectors for infrared adapter or PCC cable (programming cable) to set cabin parameters (not available on model C00)
- Programming connector (models B00 and C00)
- LON network connector (model C00)
- Palm / laptop software for parameter setting (Palm handheld/laptop required)

IC-Cable ICx-7 (interconnection cable)

- For CP-unit - I/O unit connection
- Prefabricated with plugs on both sides
- CP side plug designed to be pulled through standard installation pipe
- Halogen free and flame retarding
- Standard length is 7 meters

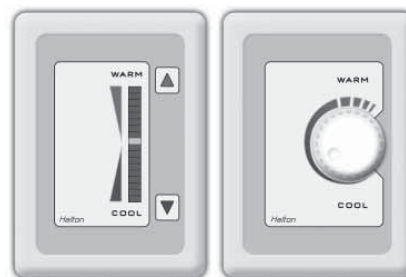

Halton control panels B00, C00 and H02

REHEATER COILS AND BOX

- Coil material incoloy 800 or equivalent
- Manual reset, safety thermostat 90 °C
- Isolating switch
- Take off/hinged doors available
- Cable glands according to customer's requirements
- IP-class 55

ACCESSORIES FOR HML AIRFLOW UNITS

LIA-1 Infrared adapter

- For connection between Palm and CP-unit to set cabin parameters. One per Palm handheld needed

PCC-cable (programming cable)

- For connection between laptop and CP-unit to set cabin parameters
- One per laptop needed

FUNCTION, CP UNIT

Control panel operates as normal wall thermostat but besides this includes a number of special features like diagnostics function, room brightness measurement and re-programmability.

The power supply and communication to the HML unit is done via IC cable.

Set point temperature is limited by minimum and maximum temperature parameters, which are software adjustable between 10 and 30 °C. LRC-1 system, will regulate room temperature regarding the temperature set point that is set with warm/cool buttons.

Regulation Diagram

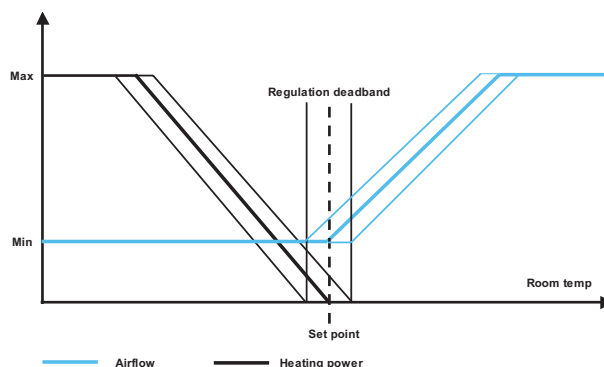

Function of VAV unit

When passenger demands lower temperature by using CP unit, the damper opens in order to increase the flow of cold air towards the maximum value. When the required temperature in the cabin is achieved, the damper reference is held until the temperature demand changes. In heating mode, the damper restricts the airflow towards its minimum rate, and if the required temperature in the cabin is not thus achieved, the controller activates the electric reheater inside the unit.

HML unit's airflow measurement accuracy

Accuracy*	±10%
* ductwork pressure 200-1000 Pa (optimal)	

Note:
When comparing airflow measurements between airflow unit and other device, unit's airflow regulation dead-band has to be taken into account (± 10%).