

HMF Single Duct Cabin Unit

for Passenger And
Crew Cabins



V1M08Y2006/Halton Marine reserves the right to alter products without notice.

The Halton HMF is an automatic or semi-automatic single duct cabin unit. Automatic operation is facilitated by continuous airflow measurement and damper regulation by intelligent CP-unit (control panel). Automatic HMF adapts to variations in ductwork pressure from 200Pa up to 1000 Pa and maintains individual conditions in each cabin and is thus pressure independent. Semi-automatic control packages do not include airflow measurement and are thus pressure dependent.

- Integrated airflow measurement with built-in heat compensation (automatic models)
- MED approved, B-0/B-15
- Damper min. / max. position settings (semi-automatic)
- Triac controlled reheating coil(s), adjustable heating power by LRC software

- 90°C manual reset safety switch with state detection to CP-unit (control panel)
- Minimum flow alarm (automatic model) and inbox temperature measurement with overheat limit to cut-off reheater power
- Inputs to connect balcony door or other external devices available as an option
- Energy saving mode to reduce unnecessary cooling / heating costs available as an option
- Master/slave functionality: several slave cabin units can be connected to one master cabin unit. The total sum of IC cable (interconnection cable) length from CP unit (Control panel) to last slave cabin unit can be up to 30 meters.
- All parameters can be preset at the factory or set onsite during commissioning by Palm handheld or Laptop computer with LRC software

PART	MATERIAL	PART	MATERIAL
Casing	Hot galvanized steel	Reheat coil	AISI 304
Spigots	Hot galvanized steel and EPDM rubber	Cables	Halogen free
Insulation	Mineral wool, s = 25 mm, MED approved	Measurement wings	Aluminium / polyurethane
I/O unit	Aluminium / plastic / electronics		

GENERAL HMF drawing

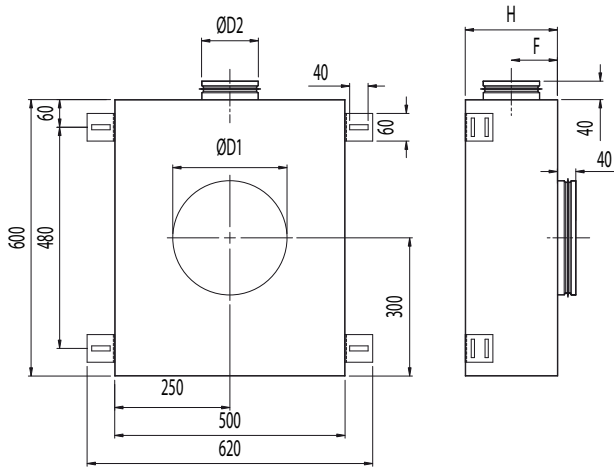

DIMENSIONS TABLE

HMF Dimensions				
	H	ØD1 male/ female	ØD2 male/ female	F
HMF-100	200	199/201	99/101	100
HMF-125	240	249/251	124/126	110

Note:
male connection: outer dimension
female connection: inner dimensions

HMF PRODUCT MODELS

Control Packages

- Automatic versions B00, C00, B01, H02
- Semi-automatic version I00

I/O unit (input/output unit, inside a cabin unit)

- 230V power supply connector
- Connector for actuator (24VAC)
- Integrated airflow measurement sensor (B00 and C00)
- Triac to control reheat coil(s)
- Connector for IC-cable
- Optional free inputs (balcony door, etc.)
- Connector for inbox temperature measurement (NTC sensor)
- Fuses to protect I/O, CP, triac and actuator
- Programming connector
- Two diagnose LEDs

CP unit (control panel)

Halton Marine HMF cabin units are available with two different control panels; push buttons and rotating knob. See configuration table on HALTON HIT.

CP unit features

- Cabin temperature measurement
- Two push buttons, 18 led bar (models B00, C00 and B01) or knob adjusting (models H02 and I00)
- Self diagnose function (models B00, C00 and B01)
- Internal fault LED
- Connector for IC-cable

- LED intensity control and auto dimming (models B00, C00 and B01)
- Connectors for infrared adapter or PCC cable (programming cable) to set cabin parameters (not available on model C00)
- Programming connector (models B00, C00 and B01)
- LON network connector (model C00)
- Palm / laptop software for parameter setting (Palm handheld / laptop required)

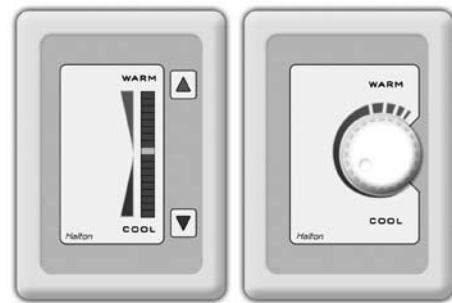

Models B00, C00, B01

Models I00, H02

Halton control panels B00, C00, B01, H02 and I00 for HMF cabin units

IC-Cable ICx-7 (interconnection cable)

- For CP-unit - I/O unit connection.
- Prefabricated with plugs on both sides
- CP side plug designed to be pulled through standard installation pipe
- Halogen free and flame retarding
- Standard length is 7 meters

ACCESSORIES FOR HMF CABIN UNITS

MS-Cable MSx-7 (master-slave cable)

- For master cabin unit - slave cabin unit/units connection
- Prefabricated with plugs on both sides
- Halogen free and flame retarding
- Standard length is 7 meters

LIA-1 Infrared adapter

- For connection between Palm and CP-unit to set cabin parameters
- One per Palm handheld needed

PCC-cable (programming cable)

- For connection between laptop and CP-unit to set cabin parameters
- One per laptop needed

Reheaters available

- 400 W
- 800 W
- 400 W + 800 W
- 1200 W

Practical power level may be software adjusted cabin by cabin. Cable and power supply design has to be done according to maximum available heating power.

Min. airflows for HMF cabin unit

Minimum airflows		
Reheater Power (W)	Min. airflows (m ³ /h)	
	HMF-100	HMF-125
0	120	150
400	120	150
800	130	150
1200	170	170

FUNCTION

Control panel operates as normal wall thermostat but besides this includes a number of special features like diagnostics function, room brightness measurement and re-programmability. The power supply comes from I/O unit (installed in cabin unit) via IC cable. Set point temperature is limited by minimum and maximum temperature parameters, which are software adjustable between 10 and 30°C. LRC-1 system, will regulate room temperature regarding the temperature set point that is set with warm/cool buttons or with the knob.

When passenger demands lower temperature by using CP unit, the damper opens in order to increase the flow of cold air towards the maximum value. When the required temperature in the cabin is achieved, the damper reference is held until the temperature demand changes. In heating mode, the damper restricts the airflow towards its minimum rate, and if the required temperature in the cabin is not thus achieved, the controller activates the electric reheater inside the unit.

Operating range for HMF

HMF	
HMF-100	HMF-125
120 m ³ /h - 350 m ³ /h	150 m ³ /h - 500 m ³ /h

Regulation Diagram

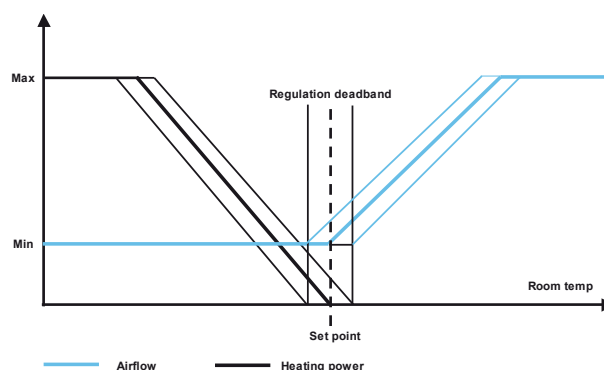

Cabin unit's airflow measurement accuracy

Airflow (m ³ /h)					
	120-150	151-200	201-300	301-400	401-500
Accuracy*	±20%	±15%	±10%	±8%	±6%
* ductwork pressure 200-1000 Pa (optimal)					

Note:

When comparing airflow measurements between cabin unit and other device, cabin unit's airflow regulation dead-band has to be taken into account (± 10 m³/h).

